

Specifications	Pro60 SE
Nominal Size	6 1/2"
RMS Power Handling	125 watts
Peak Power Handling	250 watts
Nominal Impedance	3 ohms
Frequency Response	50Hz-22kHz (±3dB)
Sensitivity	90dB (1watt @ 1meter)

#	Description	Quantity
1	Pro60 SE Woofer	2
2	Type-M1 1" Alloy Dome Tweeter	2
3	Pro60 SE Woofer Crossover	2
4	Pro60 SE Tweeter Crossover	2
5	Tweeter Grille	2
6	Tweeter Axis-Mount	2
7	Tweeter Flush-Mount	2
8	Tweeter Angle-Mount (top)	2
9	Tweeter Angle-Mount (bottom)	2
10	5 x 7" (127 x 177mm) Adapter	2
11	6" (160mm) Adapter	2
12	6 1/2" (165mm) Adapter	2
13	Woofer Gasket	2
not shown	Woofer Hardware Package	1
14	Boston Hex Tool	1
15	Woofer Grille	2
16	Small Gold Terminal	2
17	Large Gold Terminal	2
18	Crossover Bridge	2
19	1/2" (13mm) Spacer	2
not shown	11/16" Socket Button Head Screw	6
20	1/4" Socket Button Head Screw	6
not shown	Tweeter Hardware Pack	2
21	1" Socket Head Screw	4
22	Spring Clips	4
23	Terminated Tweeter Wire	2
24	Axis-Mount Stand-Off	2
25	3/8" Pan Head Screw	2
26	1" Flat Hex Head Screw	2
not shown	1/2" Pan Head Screw	2
27	11/8" Socket Button Head Screw	16
28	1 1/2" Flat Hex Head Screw	2
29	1/2" Self-Tapping Screw	4
30	1" Self-Tapping Screw	4
31	3/32" Hex Bit	1

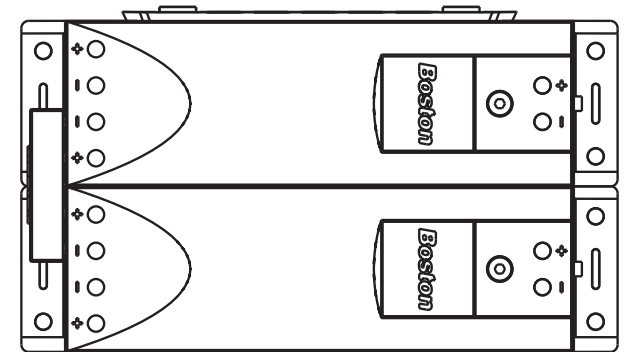
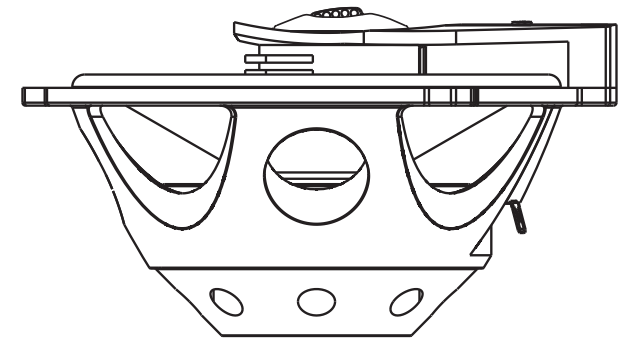
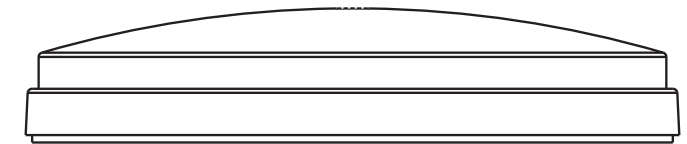
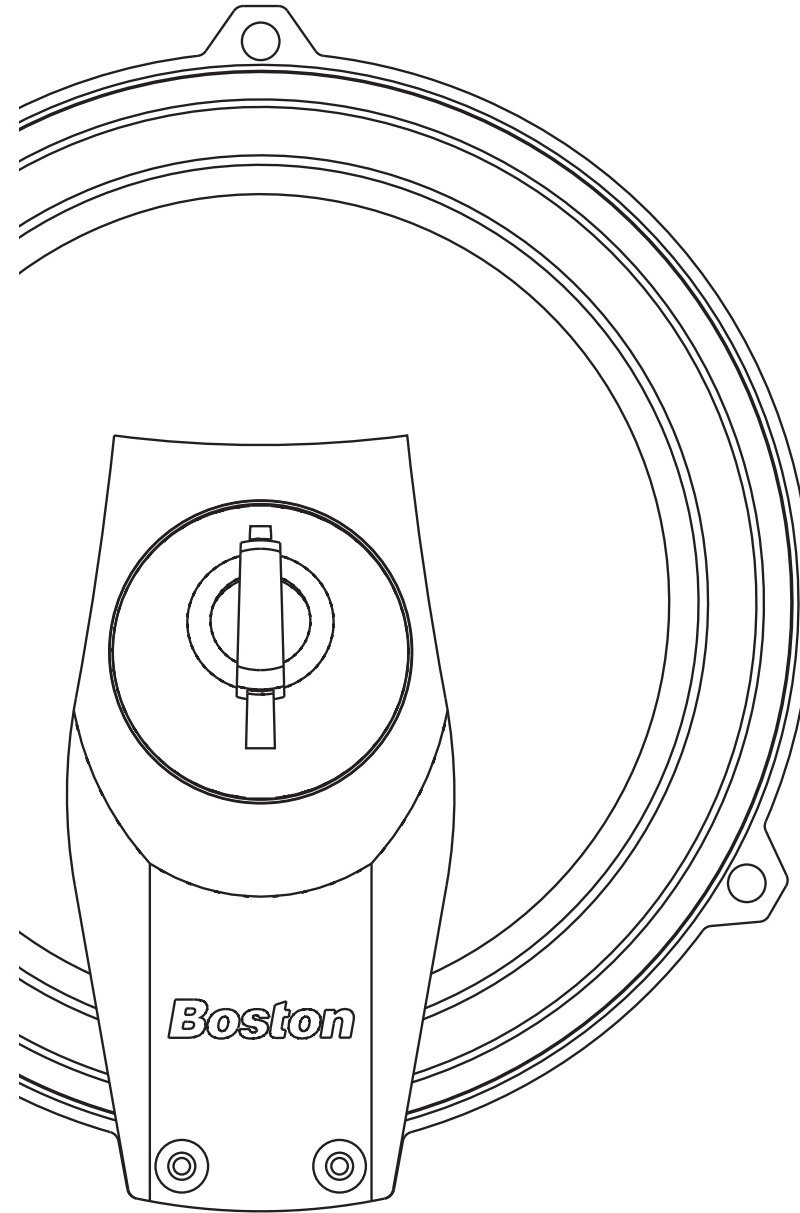
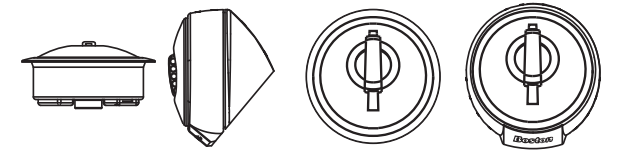

Boston Acoustics, Inc. 300 Jubilee Drive, Peabody, MA 01960 USA T: 978.538.5000 F: 978.538.5100 W: bostonacoustics.com
 Boston, Boston Acoustics, and the Boston Acoustics logo are registered trademarks of Boston Acoustics, Inc.
 Specifications are subject to change without notice.
 © 2008 Boston Acoustics, Inc. All rights reserved. Covered by patents issued and/or pending.

142-003255-0

High Performance 6 1/2-inch Component Speaker System



PRO60SE

Axis-Mount

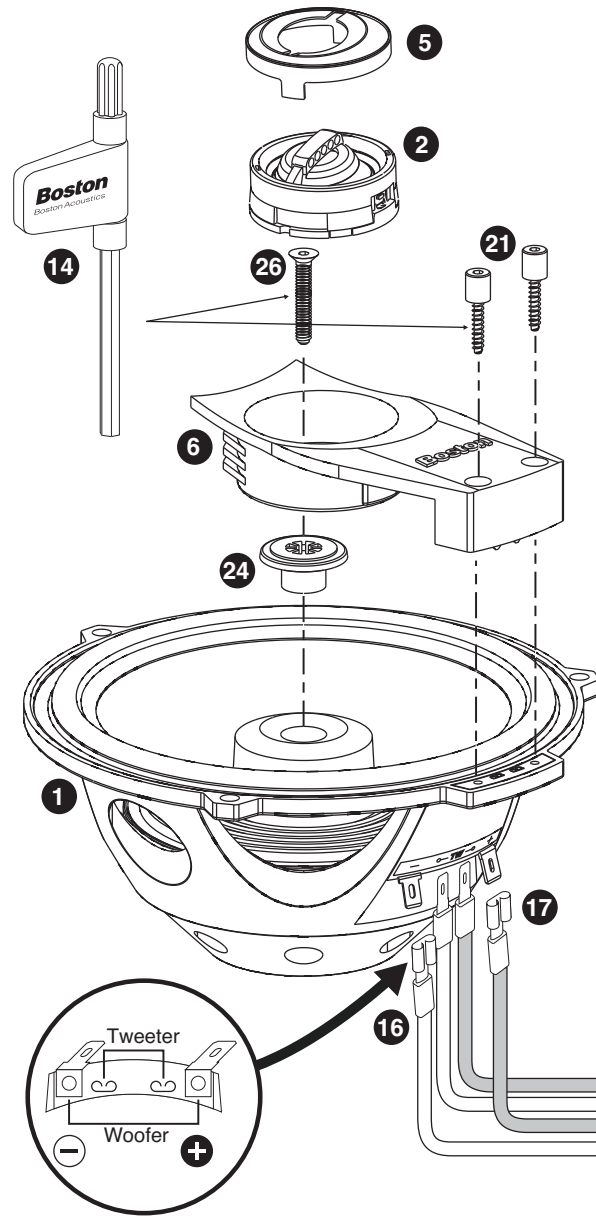

Flush-Mount

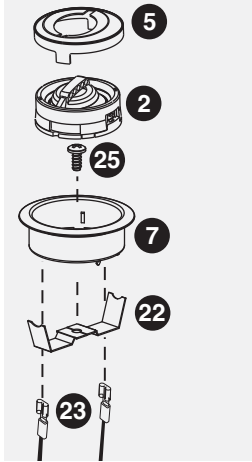

Angle-Mount

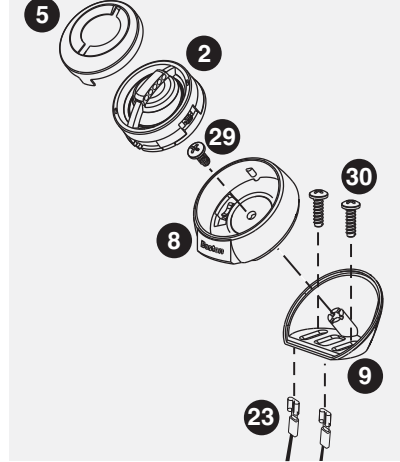

Tweeter Installation

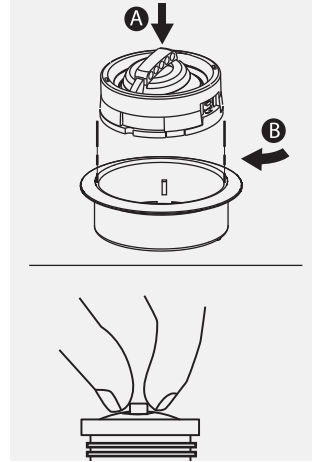

Tweeter Attenuation

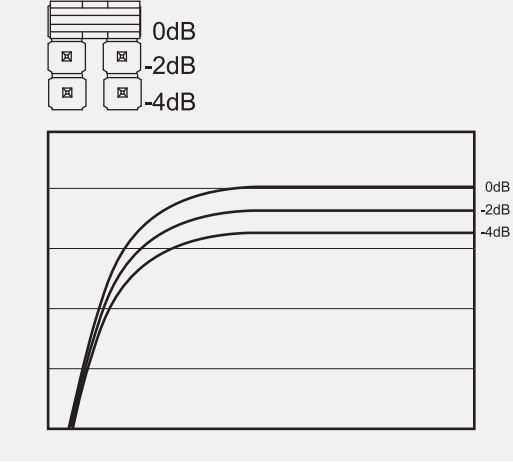

Axis / Component Configuration

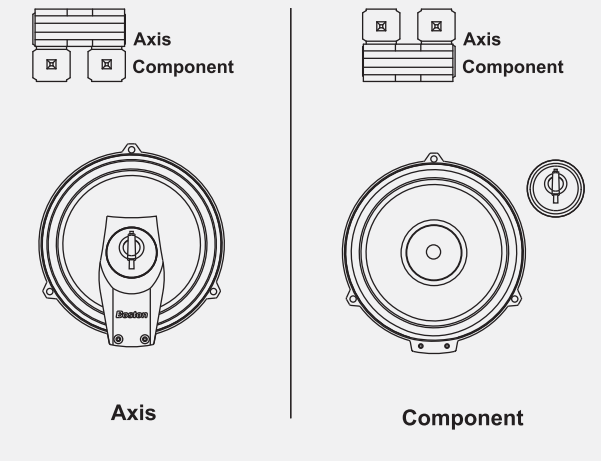

6-inch (160mm) Adapter

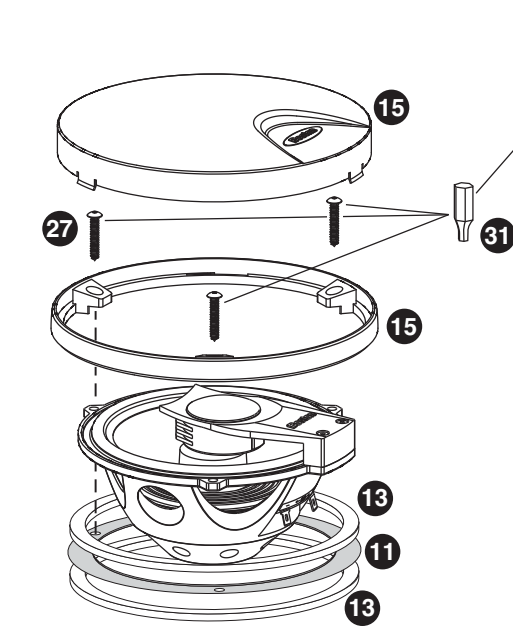

6½-inch (165mm) Adapter

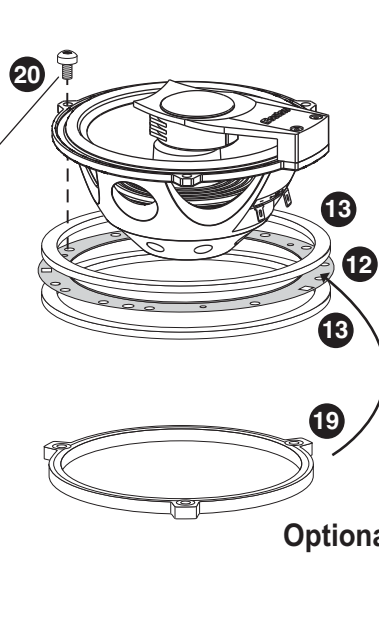

5 x 7-inch (127 x 177mm) Adapter

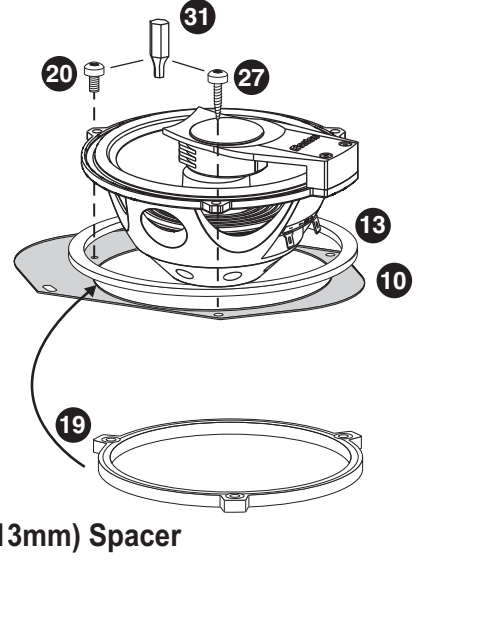

Optional ½-inch (13mm) Spacer

Key on Back Page

Signal Bridge

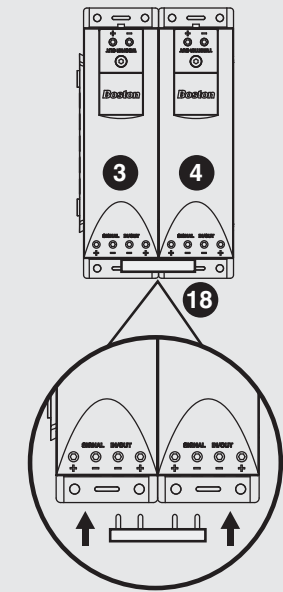

Crossover - Single Input

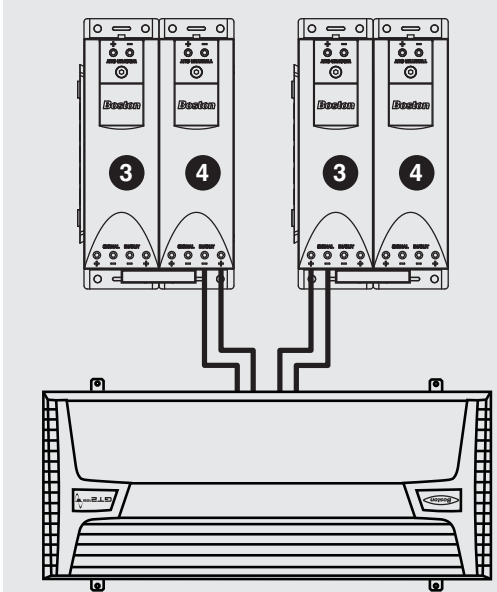

Crossover - Bi-Wire / Bi-Amp

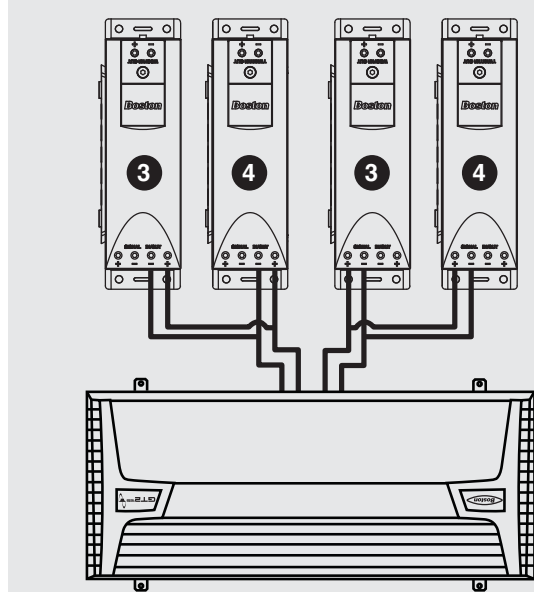

Crossover - Daisy Chain

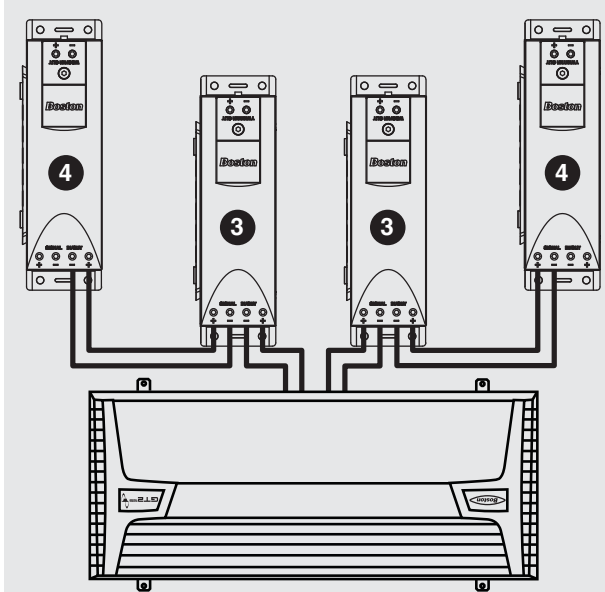

Crossover - All Connected

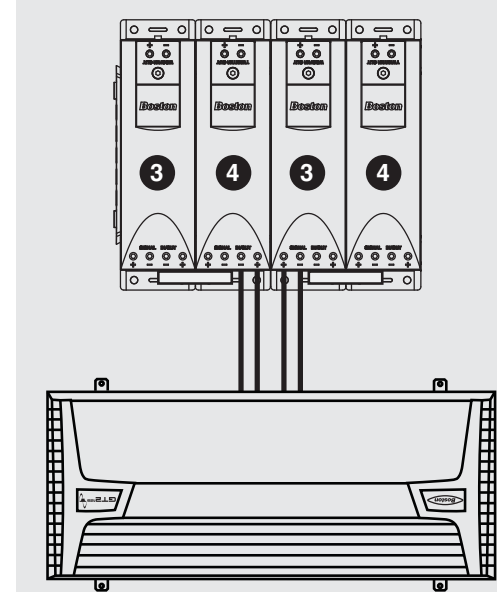

Crossover - Connection

